

Parts Catalog

60XEND

Scissors working platform

杭叉集团股份有限公司

HANGCHA GROUP CO., LTD

Contents

1 Chassis	- 2 -
1-1 Steering.....	- 2 -
1-1-1 Hub assembly.....	- 4 -
1-2 Drive part.....	- 6 -
1-3 Anti-tip assembly	- 8 -
1-4 Pedal and cover	- 10 -
1-5 Chassis parts assembly.....	- 12 -
1-6 Side door assembly	- 14 -
2 Scissor.....	- 16 -
2-1 Scissor.....	- 16 -
3 Platform.....	- 18 -
3-1 Platform assembly.....	- 18 -
3-2 Fixed platform.....	- 20 -
3-3 Mobile platform.....	- 22 -
3-4 Brake pedal assembly.....	- 24 -
4 Hydraulic system	- 26 -
4-1 Schematic diagram of hose connection.....	- 26 -
5 Electrical System	- 28 -
5-1 Distribution of electrical components.....	- 28 -
5-2 Schematic diagram of electrical connection	- 30 -
5-3 Control panel assembly.....	- 33 -
5-4 Control components.....	- 35 -

Preface

Dear customers, thank you very much for your interest in and choice of the Aerial work platform of HANGCHA GROUP CO.,LTD.

You should pay attention to the following points when using our products:

1. Comply with local laws and regulations;
2. The operation manual contains important information about the products. Please carefully read all contents of the operation manual before use. After you are familiar with and correctly understand the operation instructions of the manual, you can operate in strict accordance with the requirements of the operation manual.

3. Most possible safety hazards and operational precautions are included in the manual. However, due to the complexity and variability of actual working conditions, the manual cannot cover all risks and safety hazards. It is necessary to ensure the absolute safety of operators during the operation to ensure that the operation will not cause damage to the product.

4. The technical parameters, diagrams, forms, etc. contained in the manual are all the latest version when the manual was written. Due to the continuous update of products and technologies, the company reserves the right to update technical parameters and relevant information without prior notice. If the manual is inconsistent with the actual product, please ask our after-sales staff for the latest information.

Before you order accessories, please first confirm the following situation:

1. What kind of car is the part you want to order?
2. Which part or system do you want to order parts from?

3. After determining which part or system part, the corresponding page number is found in the parts catalogue (table);
4. The serial number of the corresponding part is found on the page number, and the name of the figure number of the part is found in the list of parts.
5. If you want to place an order, you need to tell us the quantity you need in addition to the above information.

1 Chassis

1-1 Steering

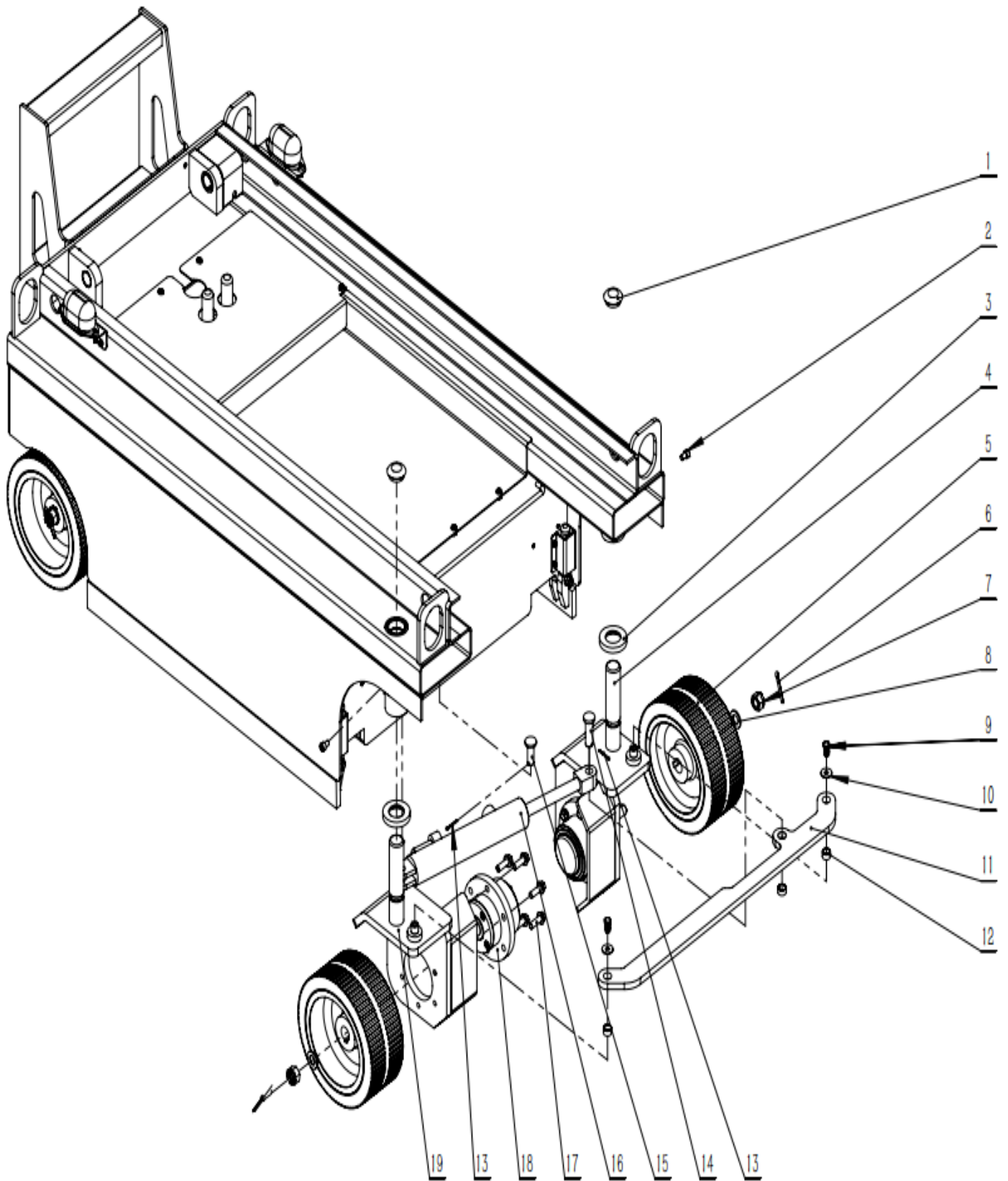

1-1 Steering

NO.	Figure number	Name	Part number	Quantity	Remarks
1	N163-800004-000	Rubber stopper	208500180050	2	
2	GB70-85	Screw M8×12	300040020176	2	Level 8.8
3	60XEND-200002-000	Copper sets	222100050005	2	
4	60XEND-210100-000	Left front wheel bracket	222100000019	1	
5	60XEND-200001-G00	Tires	221100000011	2	
6	GB91-86	Split pin 5×40	300050010056	2	
7	GB6181-86	Hexagon Slotted Nut M16	300020120005	2	Level 8
8	GB97.1-85	Washer 16	300030040005	2	
9	GB5783-86	Bolt M8×16	300010040169	2	Level 8.8
10	GB96-85	Washer 8	300030190008	2	
11	60XEND-210300-000	Steering rod	222100010014	1	
12	CT-101610-G00	Composite bushing	229000070012	3	
13	GB91-86	Pin 3×25	300050010039	2	
14	78XEN-010005-000	Cylinder head connecting pin	224000050001	1	
15	78XEN-010006-000	Cylinder seat pin	224000050002	1	
16	78XEN-620200-000	Steering cylinder	226200020001	1	
17	GB5787-86	Bolt M10×30	300010070005	12	Level 8.8
18	60XEND-LG	Wheel hub assembly		2	See1-1-1
19	60XEND-210200-000	Right front wheel bracket	222100000020	1	

1-1-1 Hub assembly

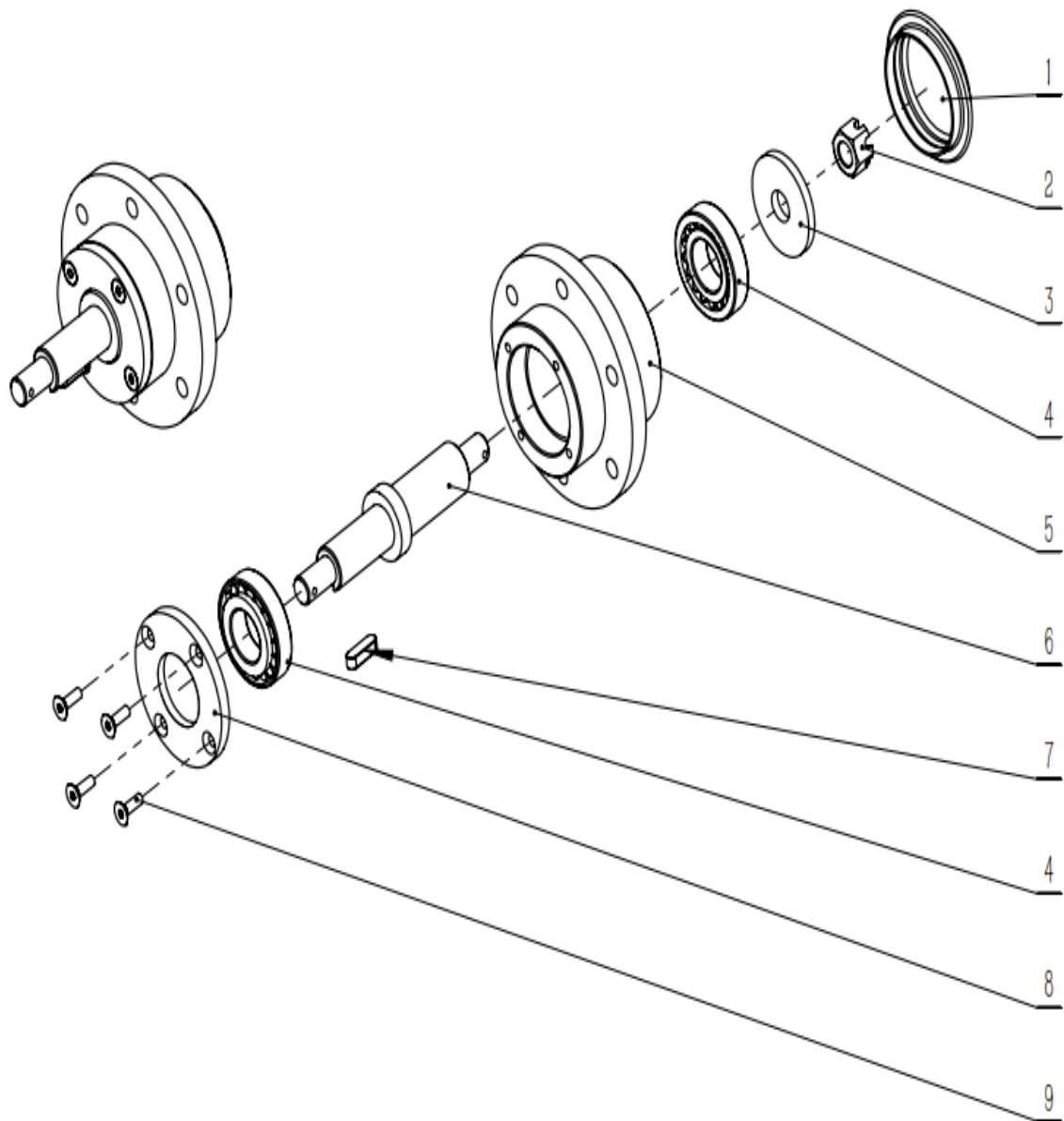

1-1-1 Hub assembly

NO.	Figure number	Name	Part number	Quantity	Remarks
1	XF150-220014-000	End cap	202200010010	1	
2	GB6181-86	Hexagon Slotted Nut M16	300020120005	1	Level 8
3	60XEND-200004-000	Bearing gasket	222100050004	1	
4	GB/T297-94	Bearing 30206	300140020020	2	
5	60XEND-200003-000	Wheel hub	222100040010	1	
6	60XEND-210400-000	Tire axle	222100030013	1	
7	GB1096-79	Key A8×28	300240010006	1	
8	60XEND-200006-000	Front cover	222100010015	1	
9	GB/T70.3-2008	Screw M6×20	300040040027	4	Level 8.8

1-2 Drive part

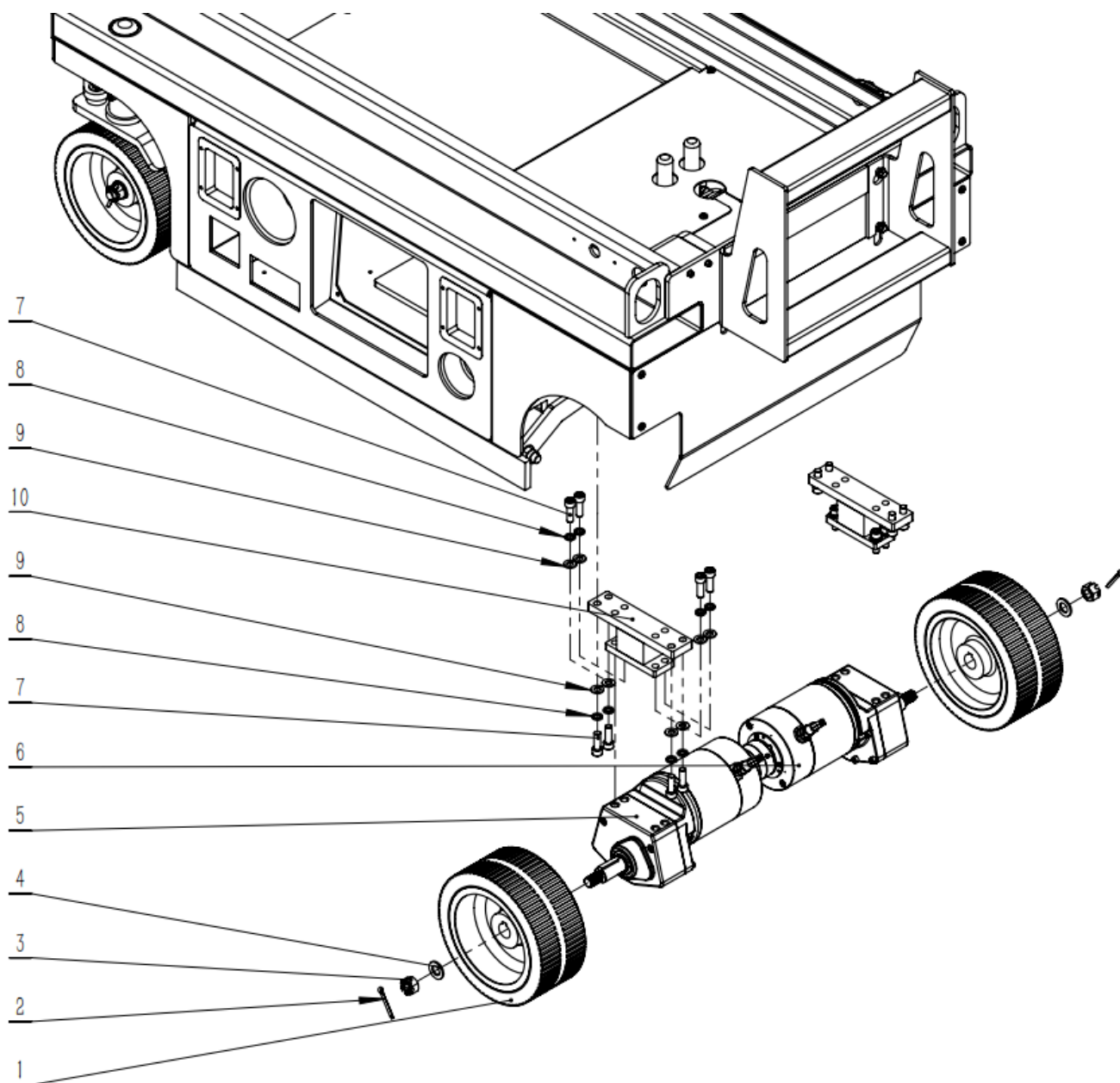

1-2 Drive part

NO.	Figure number	Name	Part number	Quantity	Remarks
1	60XEND-200001-G00	Tires	221100000011	2	
2	GB91-86	Split pin 5×40	300050010056	2	
3	GB6181-86	Hexagon Slotted Nut M16	300020120005	2	Level 8
4	GB97.1-85	Washer 16	300030040005	2	
5	60XEND-760300-G00	Left travel motor	227700020003	1	
6	60XEND-760400-G00	Right travel motor	227700020004	1	
7	GB70-85	Screw M10×30	300040020075	16	Level 8.8
8	GB93-87	Washer 10	300030010001	16	
9	GB97.1-85	Washer 10	300030040002	16	
10	60XEND-440100-000	Motor base assembly	224000000039	2	

1-3 Anti-tip assembly

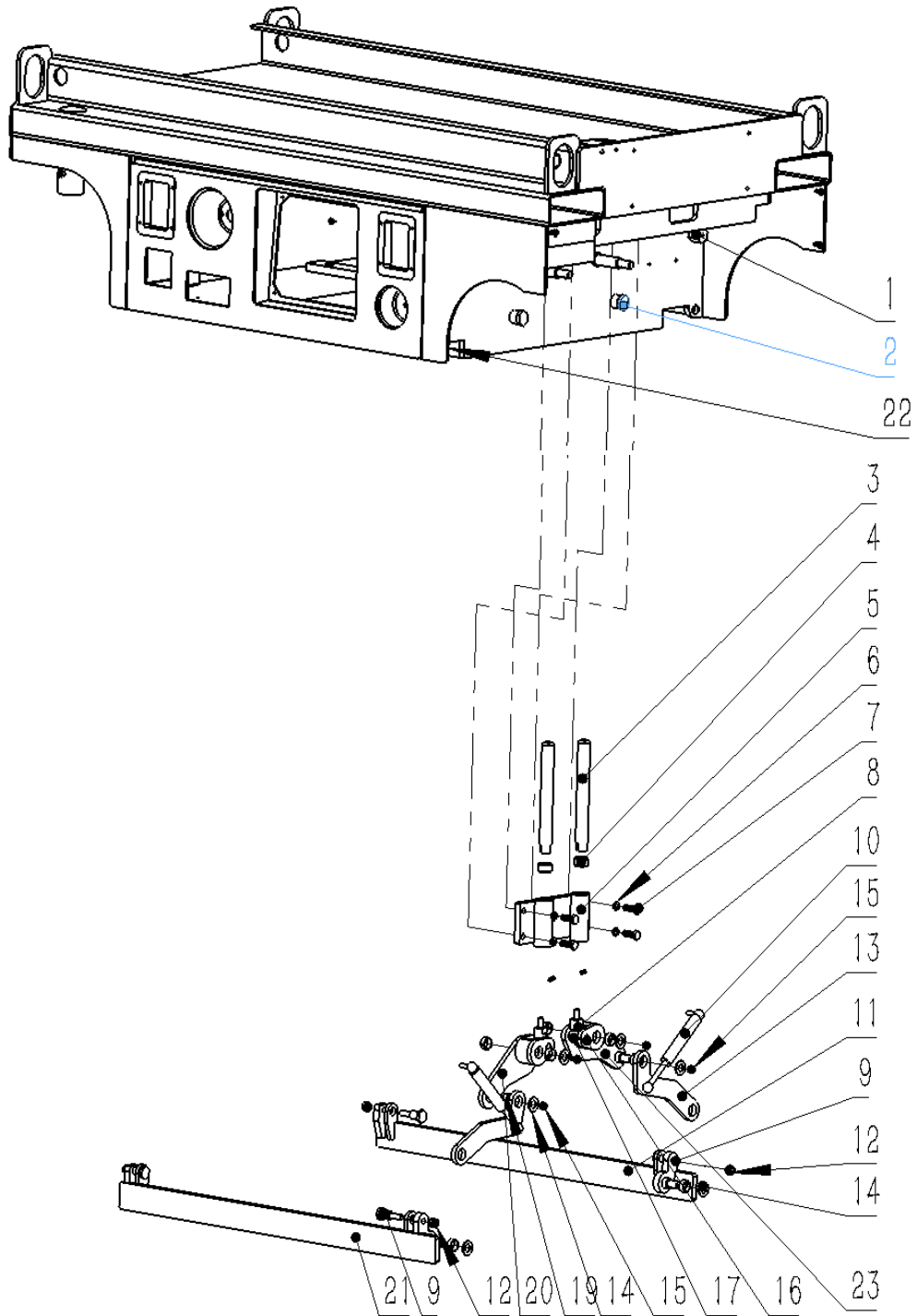

1-3 Anti-tip assembly

NO.	Figure number	Name	Part number	Quantity	Remarks
1	60XEND-400001-000	Gas spring mount	224500020012	2	
2	60XEND-400002-000	Anti-tilt limit block	224500020013	2	
3	60XEND-450005-000	Anti-tilt column	224500010016	2	
4	CT-112515-G00	Bushing 2515	229000070007	4	
5	60XEND-450600-000	Fixed sleeve	224500000029	1	
6	GB93-87	Washer 10	300030010001	4	
7	GB5783-86	Bolt M10×30	300010040011	4	
8	60XEND-450006-000	Column hexagon head	224500010017	2	
9	60XEND-450001-000	Pin bolt	224500010019	4	
10	60XEND-450007-G00	Gas Spring	224500000032	2	
11	60XEND-450200-000	Right anti-roll bar	224500000030	1	
12	GB889-86	Nut M10	300020150003	4	
13	60XEND-450002-000	Connecting plate	224500030008	2	
14	GB97.1-85	Washer 14	300030040004	6	
15	GB889-86	Nut M14	300020150007	6	
16	60XEND-450003-000	Crankshaft	224500010018	2	
17	60XEND-450004-000	Crank roller	224500020015	2	
18	GB/T78-2007	Set screw M6×16	300040060008	2	
19	CT-102010-G00	Bush 2010	224000080002	8	
20	60XEND-450500-000	Left curved stick	224500030007	1	
21	60XEND-450100-000	Left anti-roll bar	224500000031	1	
22	CT-101610-G00	Composite bushing	229000070012	4	
23	60XEND-450400-000	Right curved stick	224500030006	1	

1-4 Pedal and cover

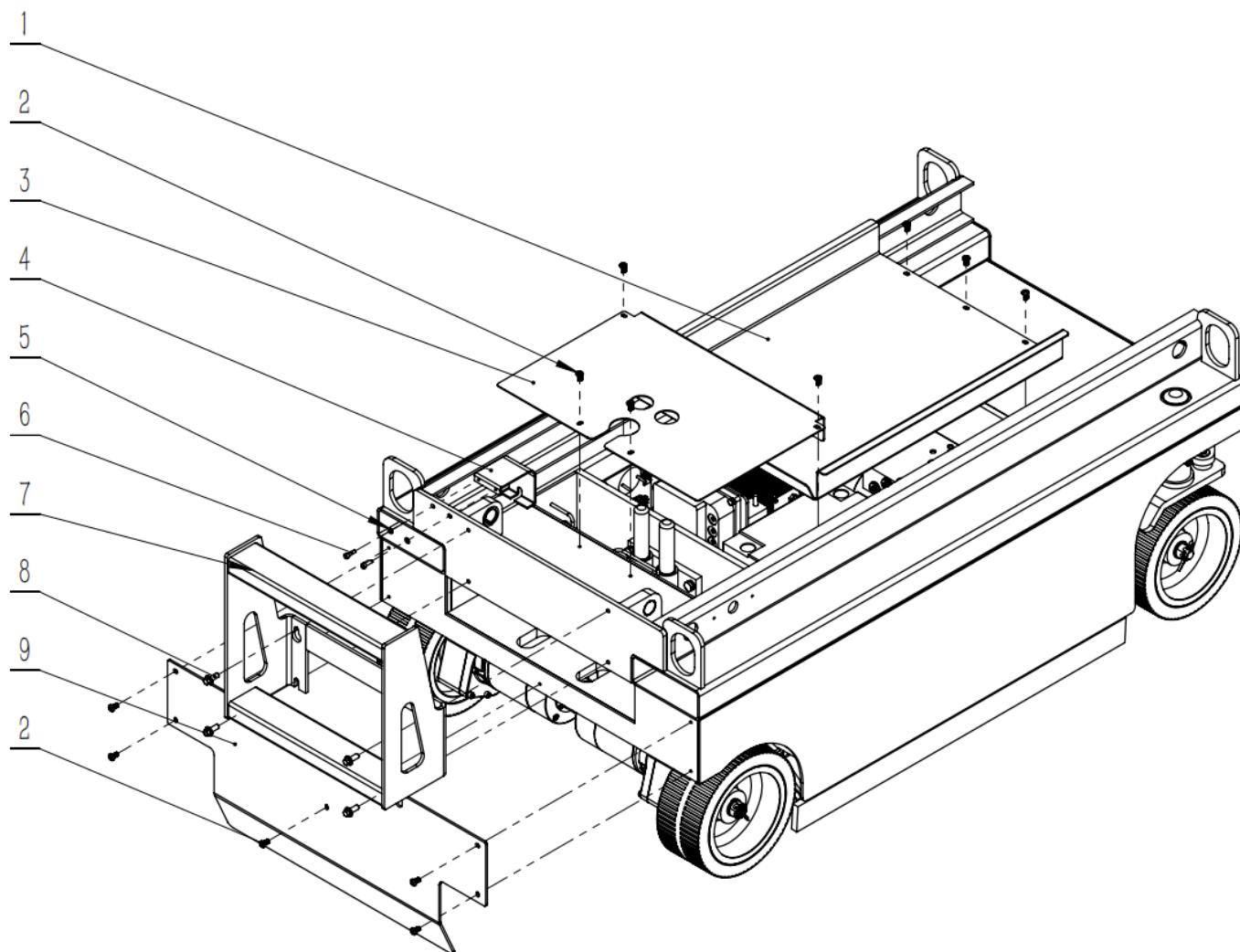

1-4 Pedal and cover

NO.	Figure number	Name	Part number	Quantity	Remarks
1	60XEND-400005-000	Top front cover	224000040062	1	
2	GB818-85	Screw M6×12	300040070012	12	
3	60XEND-400004-000	Top rear cover	224000040061	1	
4	60XEND-400008-000	Potentiometer cover	224000040064	1	
5	GB97.1-85	Washer 5	300030040012	2	
6	GB70-85	Screw M5×16	300040020149	2	Level 8.8
7	60XEND-440300-000	Pedal assembly	224400000005	1	
8	GB5787-86	Bolt M8×20	300010070025	4	Level 8.8
9	60XEND-400003-000	Rear cover	224000040060	1	

1-5 Chassis parts assembly

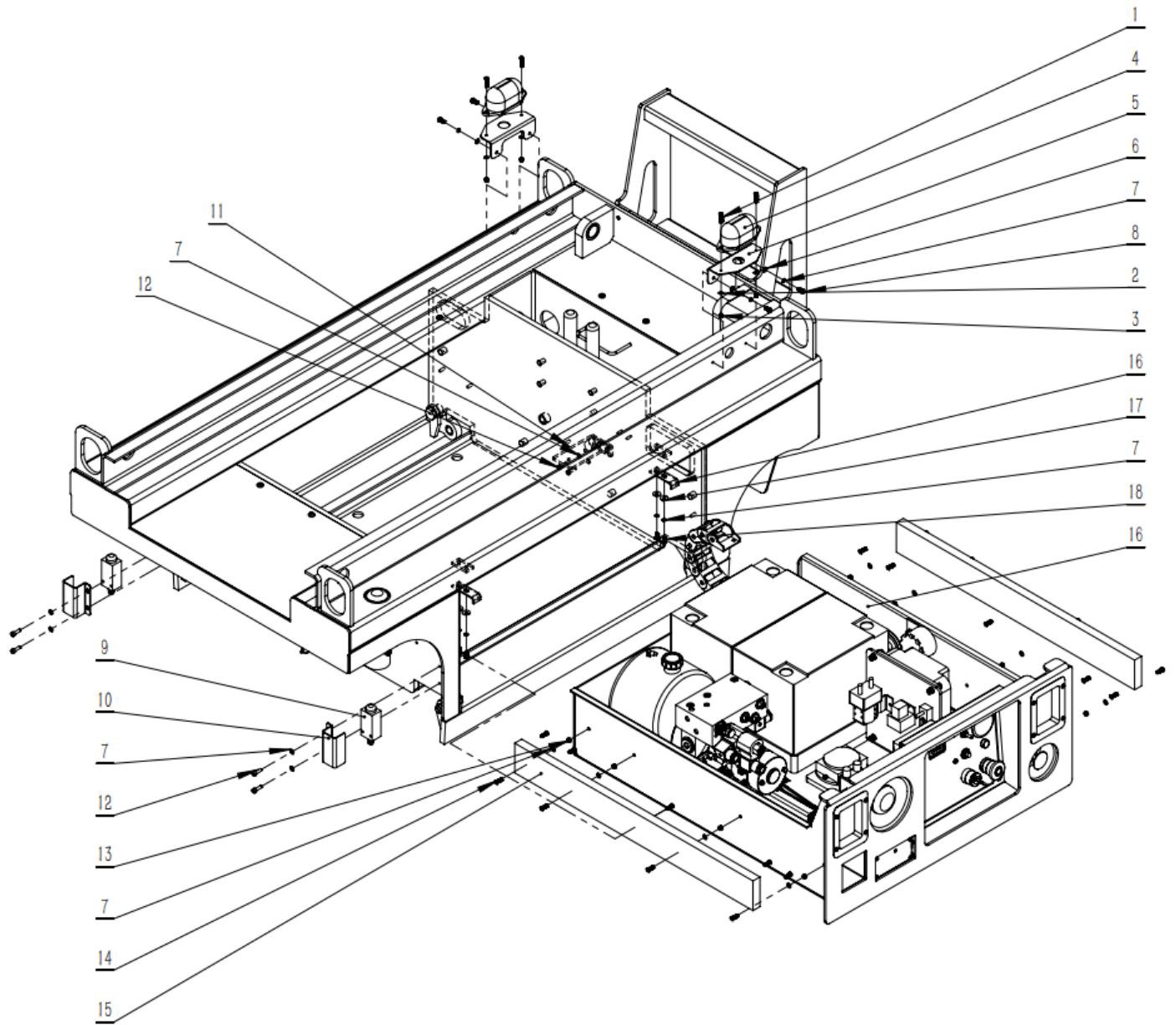

1-5 Chassis parts assembly

NO.	Figure number	Name	Part number	Quantity	Remarks
1	GB818-85	Screw M4×20	300040070034	4	
2	GB97.1-85	Washer 4	300030040011	4	
3	GB889-86	Nut M4	300020150008	4	
4	78XEN-741101-G01	Small warning light	227000010007	2	
5	78XEN-741102-000	Police light base	227000070013	2	
6	GB97.1-85	Washer 5	300030040012	18	
7	GB93-87	Washer 5	300030010013	6	
8	GB818-85	Screw M5×12	300040070008	4	
9	78XEN-740600-G00	Micro switch assembly	227200050001	2	
10	60XEND-400007-000	Anti-tilt switch cover	224000040066	2	
11	60XEND-400009-000	Drag chain seat	224000040065	1	
12	GB70-85	Screw M5×16	300040020149	6	
13	GB6170-86	Nut M5	300020010015	8	
14	GB819-85	Screw M5×16	300040280015	18	
15	76XEND-420300-000	Slide	224000000040	2	
16		Side door assembly		1	See 1-6 for details
17	GB96-85	Washer 5	300030190006	2	
18	GB5783-86	Bolt M5×10	300010040135	2	Level 8.8

1-6 Side door assembly

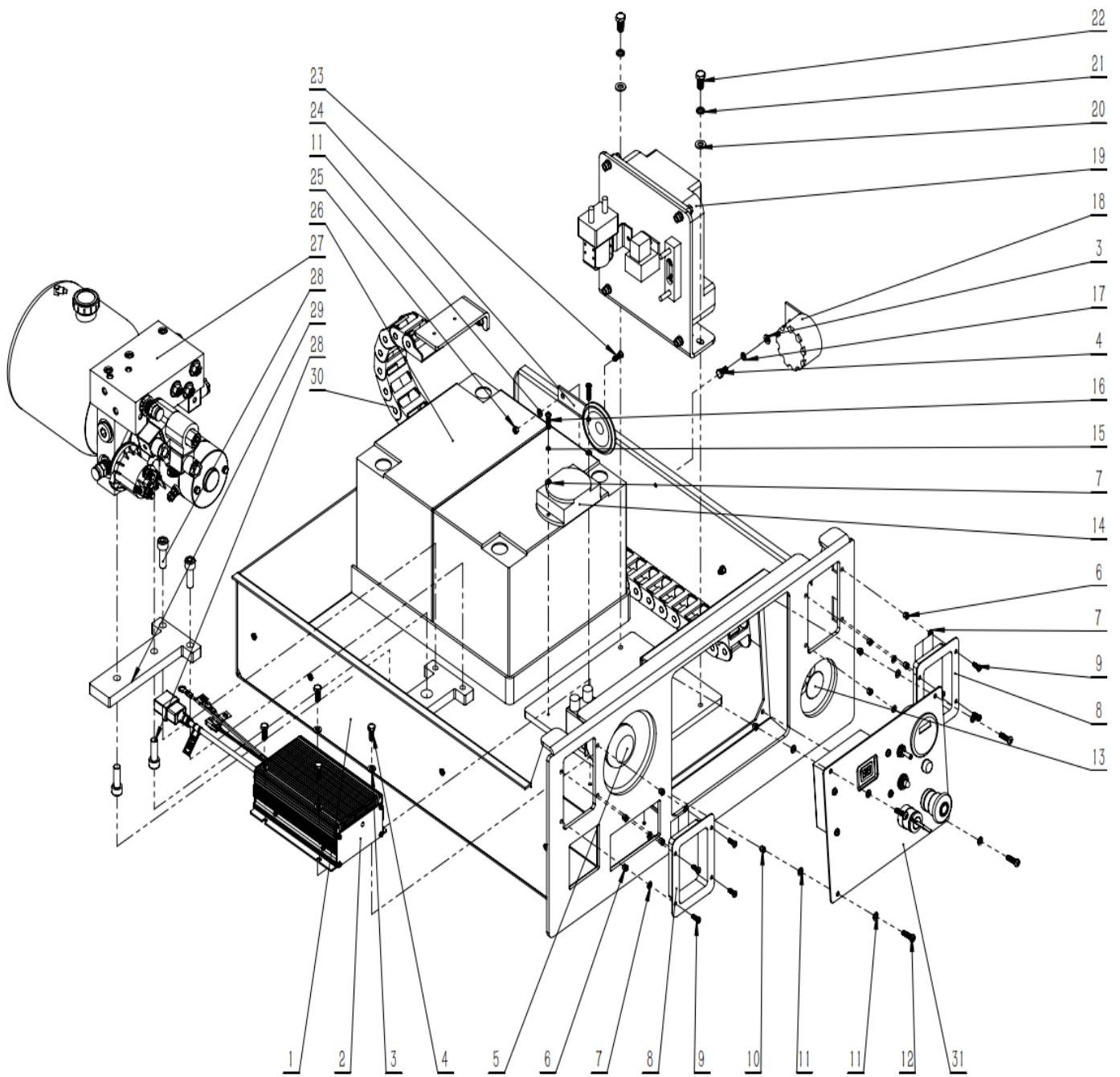

1-6 Side door assembly

NO.	Figure number	Name	Part number	Quantity	Remarks
1	60XEND-420100-000	Side door	224200000007	1	
2	60XEND-760200-G00	Charger	227800010003	1	
3	GB97.1-85	Washer 6	300030040013	5	
4	GB5783-86	Bolt M6×16	300010040148	5	
5	78XEN-740300-G00	Main power switch	227200010001	1	
6	GB889-86	Nut M4	300020150008	8	
7	GB97.1-85	Washer 4	300030040011	9	
8	78XEN-040100-000	Door lock	224000100001	2	
9	GB818-85	Screw M4×12	300040070036	8	
10	GB6170-86	Nut M5	300020010015	4	
11	GB97.1-85	Washer 5	300030040012	9	
12	GB818-85	Screw M5×20	300040070009	4	
13	60XEND-640200-000	Pull line	226000050005		
14	78XEN-740700-G00	Angle sensor assembly	227400010009	1	
15	GB93-87	Washer 4	300030010012	2	
16	GB818-85	Screw M4×20	300040070034	2	
17	GB93-87	Washer 6	300030010014	1	
18	78XEN-740800-G00	Buzzer	227000020001	1	
19		Control components			
20	GB97.1-85	Washer 8	300030040014	2	
21	GB93-87	Washer 8	300030010015	2	
22	GB5783-86	Bolt M8×16	300010040169	2	Level 8.8
23	GB819-85	Screw M5×16	300040280015	1	
24	78XEN-741000-G00	Horn	227000030001	1	
25	GB97.1-85	Washer 5	300030040012	1	
26	60XEND-760100-G00	Maintenance-free battery	227600020003	1	
27	60XEND-610000-000	Power unit	226500000001	1	
28	GB70-85	Screw M10×30	300040020075	4	
29	60XEND-420113-000	Power unit seat	224200010022	1	
30	60XEND-420201-000	Drag chain	224000130002	1	
31	60XEND-740500-000	Control panel assembly	227500000004	1	

2 Scissor

2-1 Scissor

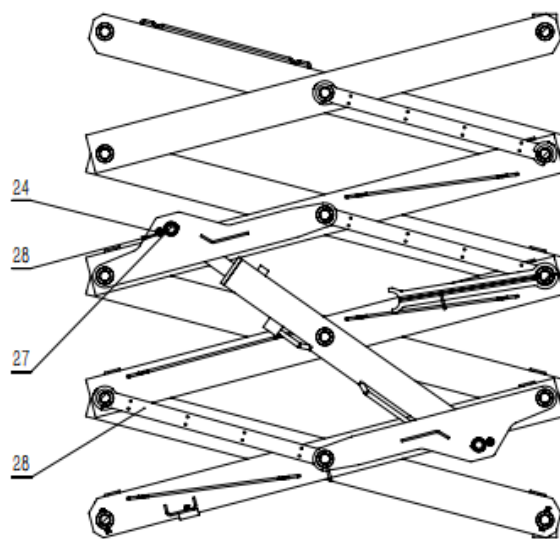
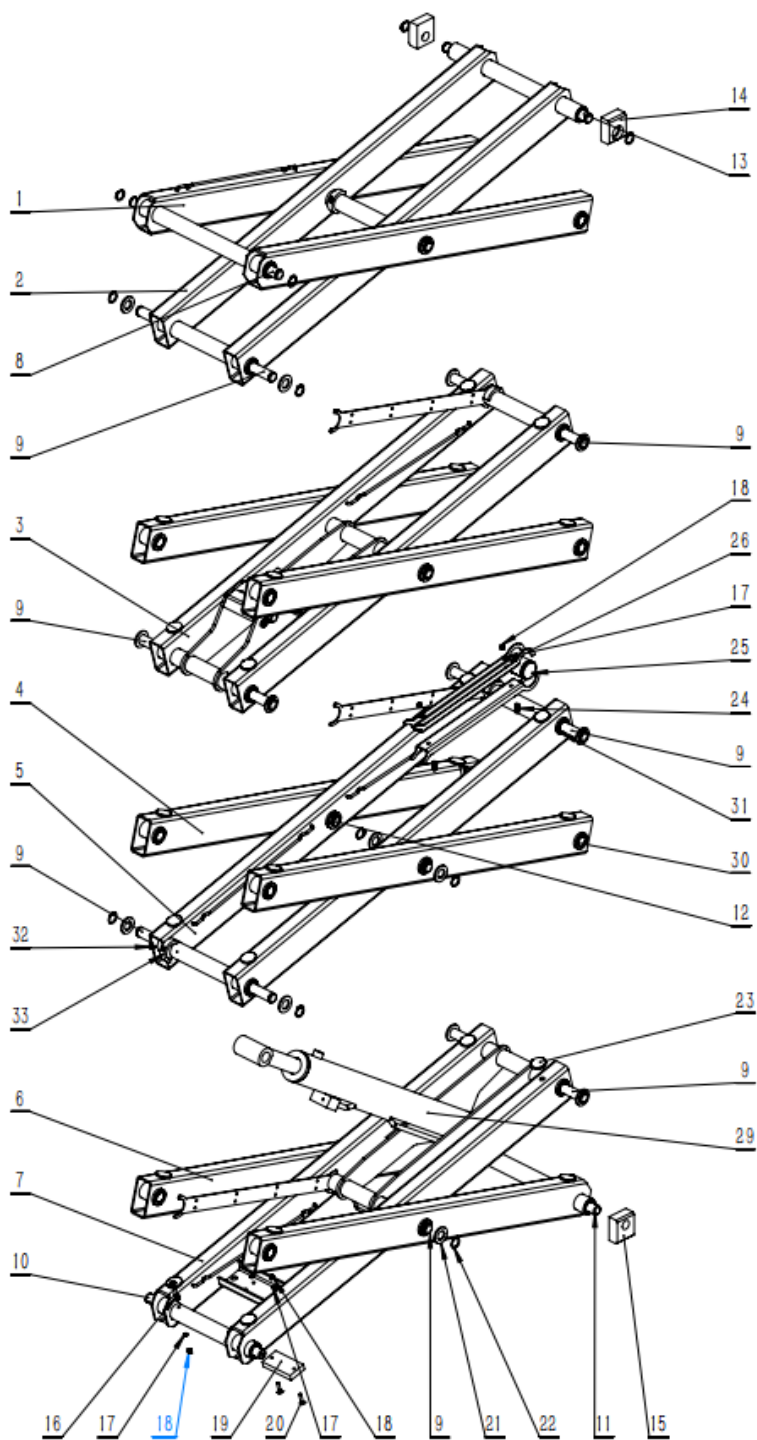

2-1 Scissor

NO.	Figure number	Name	Part number	Quantity	Remarks
1	60XEND-920200-000	Top frame	229100000073	1	
2	60XEND-910400-000	Stent D	229100000072	1	
3	60XEND-910300-000	Stent C	229100000071	1	
4	60XEND-920300-000	Outer frame	229100000074	4	
5	60XEND-910200-000	Stent B	229100000069	1	
6	60XEND-920100-000	Bottom frame	229100000068	1	
7	60XEND-910100-000	Stent A	229100000067	1	
8	60XEND-900600-000	Top fixing pin	229000050062	1	
9	60XEND-900100-000	Long pin	229000050057	9	
10	60XEND-900300-000	Bottom fixed pin	229000050059	1	
11	60XEND-900400-000	Bottom mobile pin	229000050060	1	
12	60XEND-900200-000	Short pin	229000050058	2	
13	60XEND-900700-000	Top mobile pin	229000050063	1	
14	60XEND-800003-000	Mobile slider	228000060004	2	
15	60XEND-901000-000	Bottom slider	229000090014	2	
16	GB/T 16674.1-2016	Bolt M6×50	300010070037	4	Level 8.8
17	GB97.1-85	Washer 6	300030040013	10	
18	GB889-86	Nut M6	300020150005	8	Level 8
19	60XEND-901100-000	Cushion	229000090015	1	
20	GB/T70.3-2008	Screw M6×30	300040040029	2	Level 8.8
21	GB97.1-85	Washer 24	300030040007	22	
22	JB/ZQ 4342-2006	Circlip for heavy shaft 25	300060100005	26	
23	60XEND-901200-000	Scissor block	229000100002	24	
24	GB5783-86	Bolt M6×20	300010040151	4	Level 8.8
25	60XEND-901500-000	Spacer	229000090017	2	
26	60XEND-900900-000	Maintenance arm	229000040045	2	
27	60XEND-900500-000	Cylinder pin	229000050061	2	
28	TZ010-106050-000	Lock pin	229000110003	2	
29	60XEND-620100-000	Lifting cylinder	226200010007	1	
30	CT-102525-G00	Bushing	224000080003	44	
31	CT-225215-G00	Flanging bush	229000070011	26	
32	GB/T70.3-2008	Screw M6×16	300040040026	4	
33	60XEND-901300-000	Buckle	229000090016	4	

3 Platform

3-1 Platform assembly

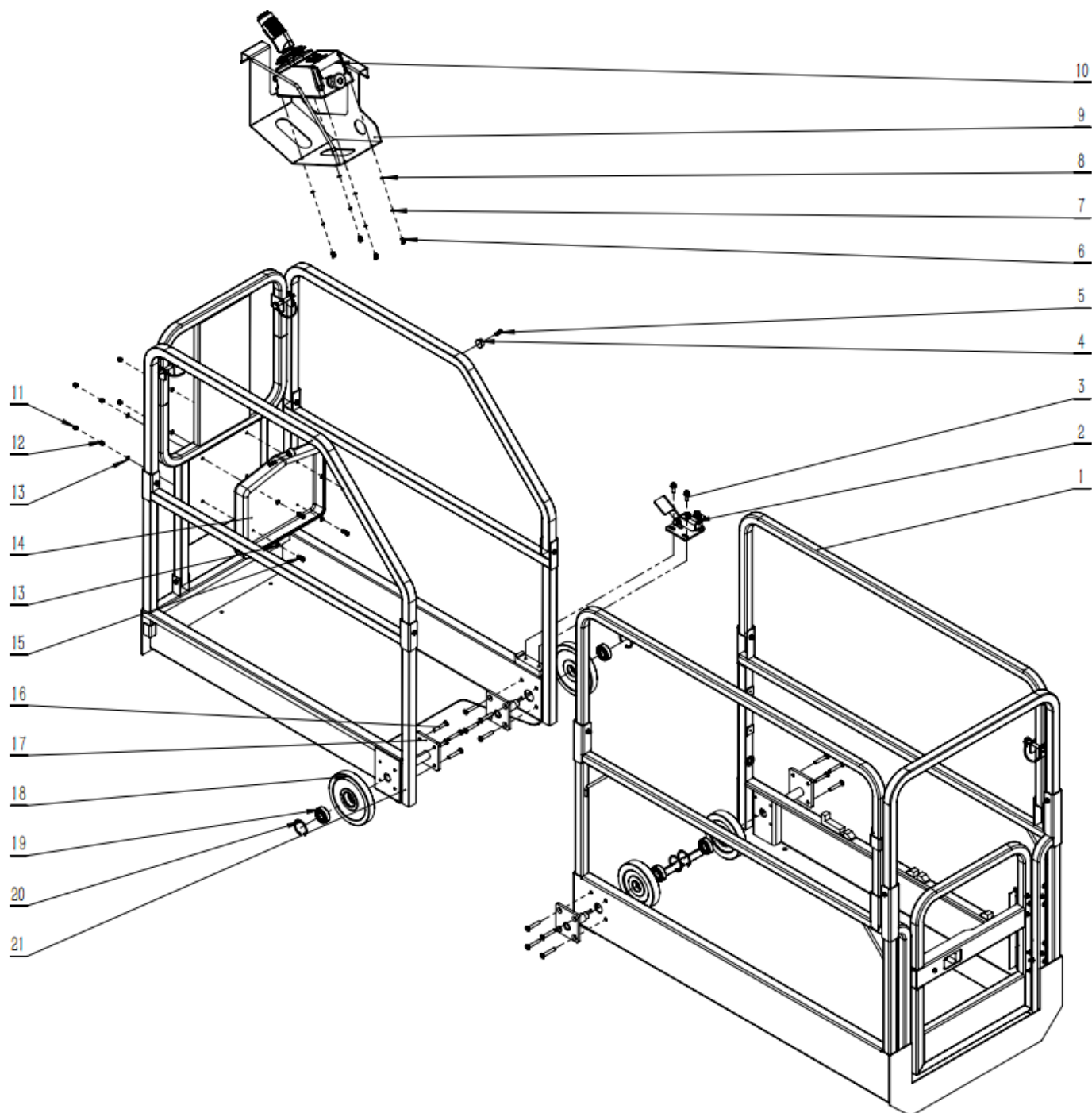

3-1 Platform assembly

NO.	Figure number	Name	Part number	Quantity	Remarks
1	60XEND-810000-000	Fixed platform	228100000036	1	See 3-2
2	60XEND-801000-000	Brake pedal assembly	228000000021	1	See 3-4
3	GB5787-86	Bolt M8×20	300010070025	2	Level 8.8
4	60XEND-800012-000	Rubber mat	228000070001	2	
5	GB818-85	Screw M5×20	300040070009	2	
6	GB818-85	Screw M5×12	300040070008	4	
7	GB93-87	Washer 5	300030010013	4	
8	GB97.1-85	Washer 5	300030040012	4	
9	60XEND-800400-000	Handle bracket	228000000018	1	
10	78XEN-750000-G00	Handle	227500030001	1	
11	GB/T 923-2009	Hexagon Cap Nut M6	300020420005	4	
12	GB889-86	Nut M6	300020150005	4	Level 8
13	GB97.1-85	Washer 6	300030040013	8	
14	78XEN-820100-G00	File box	228000000009	1	
15	GB5783-86	Bolt M6×20	300010040151	4	Level 8.8
16	GB/T70.3-2000	Screw M8×45	300040040004	16	Level 8.8
17	60XEND-800500-000	Roller bracket body	228000000019	4	
18	60XEND-800001-000	Big roller	228000050002	4	
19	GB/276-94	Bearing 6204-Z	300140010001	4	
20	GB893.1-86	Circlip for hole-A type 47	300060010015	4	
21	60XEND-820100-000	Mobile platform	228200000009	1	

3-2 Fixed platform

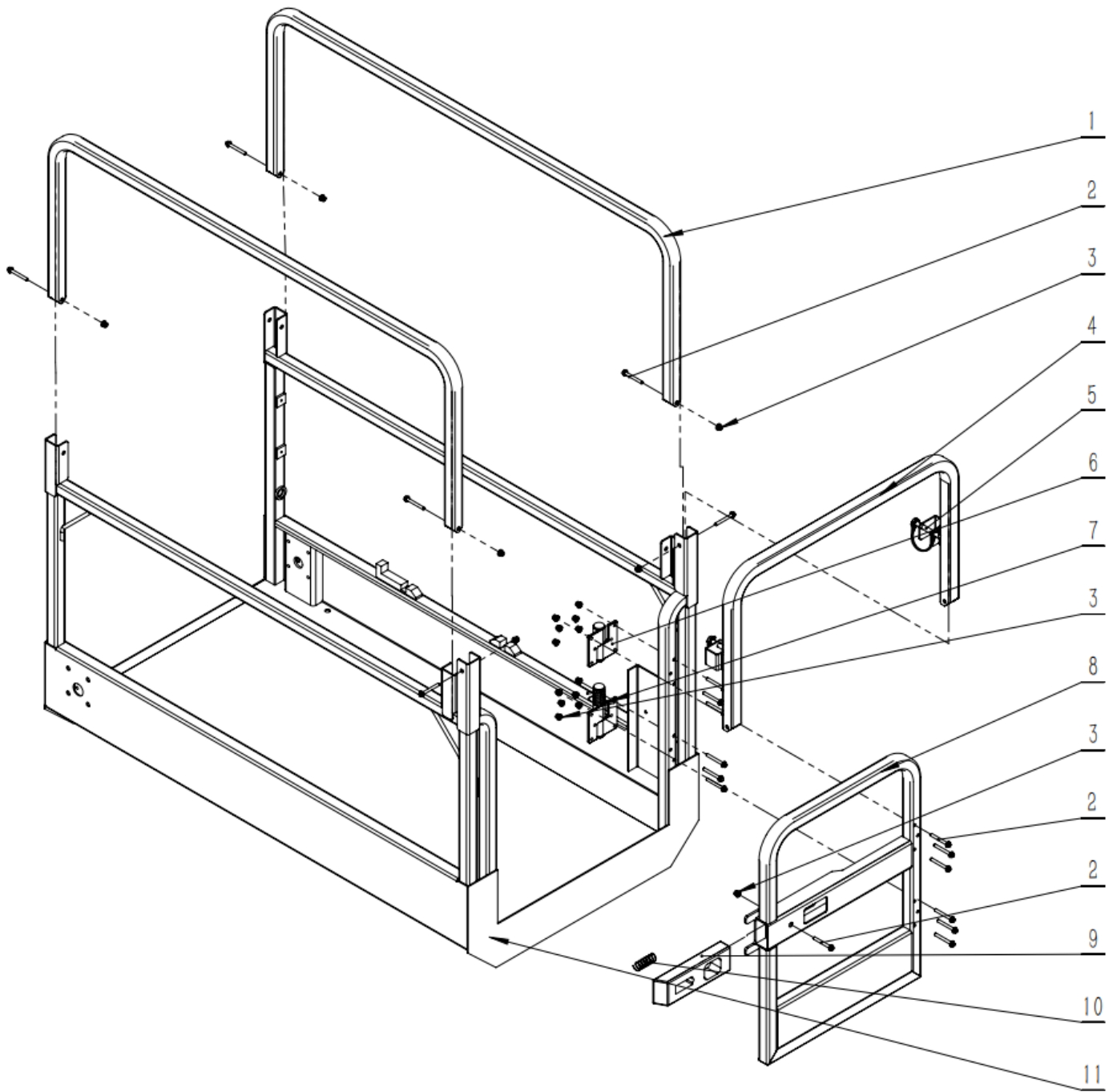

3-2 Fixed platform

NO.	Figure number	Name	Part number	Quantity	Remarks
1	60XEND-810401-000	Guardrail elbow on fixed platform	228100050047	2	
2	GB/T 16674.1-2016	Bolt M6×50	300010070037	18	Level 8.8
3	GB6183-86	Nut M6	300020490002	18	Level 8
4	60XEND-810600-000	Fixed platform rear guardrail	228100000034	1	
5	60XEND-800010-000	D type pin	228000000026	2	
6	60XEND-806001-000	Side door hinge (short)	228000000024	1	
7	60XEND-806002-000	Side door hinge	228000000025	1	
8	60XEND-810700-000	Platform side door	228100000035	1	
9	140XEN-800001-000	Plastic bolt	228000060006	1	
10	140XEN-800009-000	Spring	228000000039	1	
11	60XEND-810100-000	Fixed platform	228100000031	1	

3-3 Mobile platform

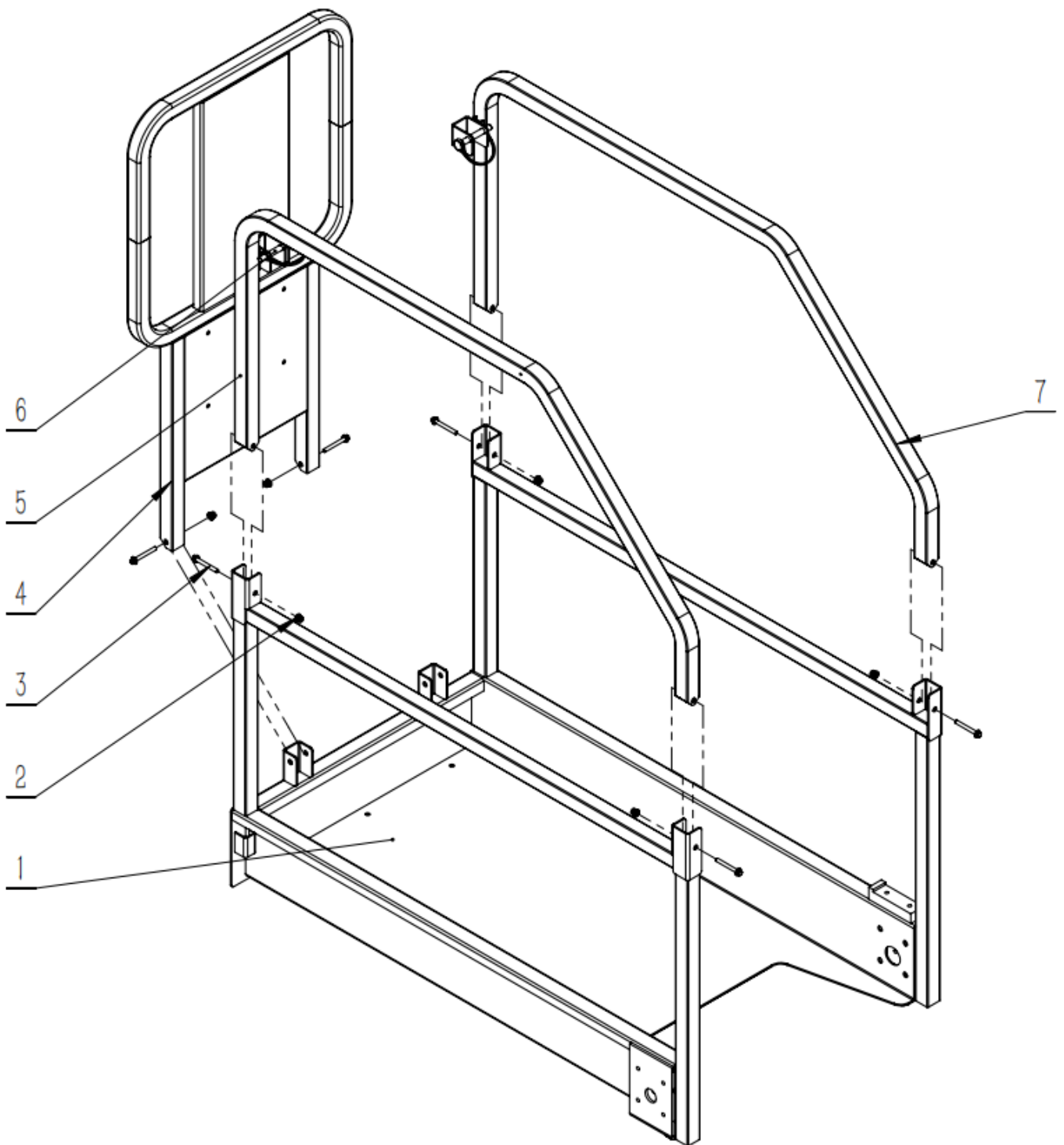

3-3 Mobile platform

NO.	Figure number	Name	Part number	Quantity	Remarks
1	60XEND-820100-000	Mobile platform	228200000009	1	
2	GB6183-86	Nut M6	300020490002	6	Level 8
3	GB/T 16674.1-2016	Bolt M6×50	300010070037	6	Level 8.8
4	60XEND-820600-000	Mobile platform front guardrail	228200000015	1	
5	60XEND-820400-000	Mobile platform upper left guardrail	228200000012	1	
6	60XEND-800010-000	D type pin	228000000026	2	
7	60XEND-820500-000	Mobile platform upper right guardrail	228200000013	1	

3-4 Brake pedal assembly

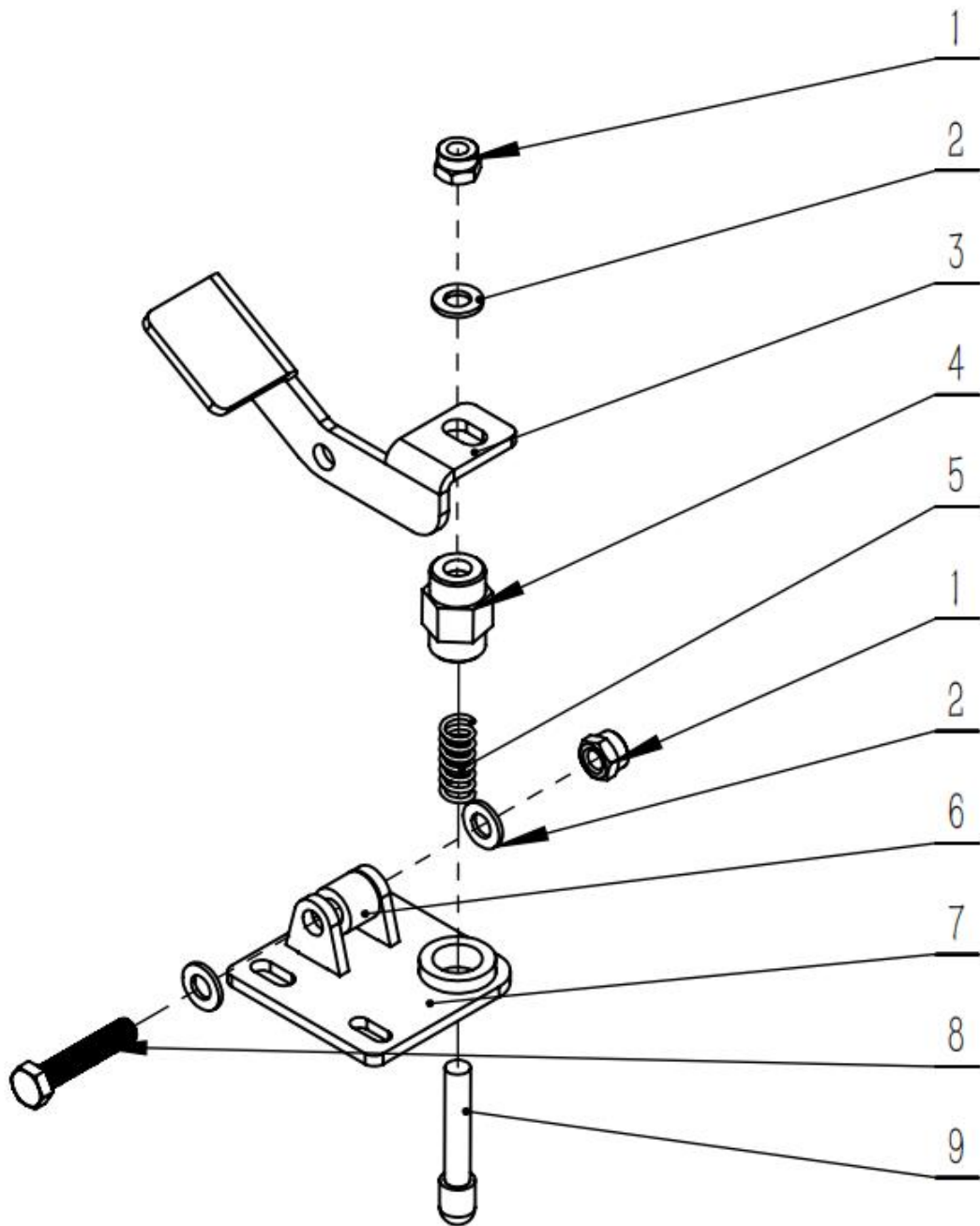

3-4 Brake pedal assembly

NO.	Figure number	Name	Part number	Quantity	Remarks
1	GB889-86	Nut M10	300020150003	2	
2	GB97.1-85	Washer 10	300030040002	3	
3	60XEND-800201-000	Pedal	228000020011	1	
4	60XEND-800104-000	Threaded sleeve	228000080005	1	
5	60XEND-800005-000	Spring	228000000014	1	
6	60XEND-800202-000	Spacer	228000080006	1	
7	60XEND-800100-000	Brake base	228000000017	1	
8	GB5783-86	Bolt M10×50	300010040019	1	Level 8.8
9	60XEND-800004-000	Positioning pin	300010040019	1	

4 Hydraulic system

4-1 Schematic diagram of hose connection

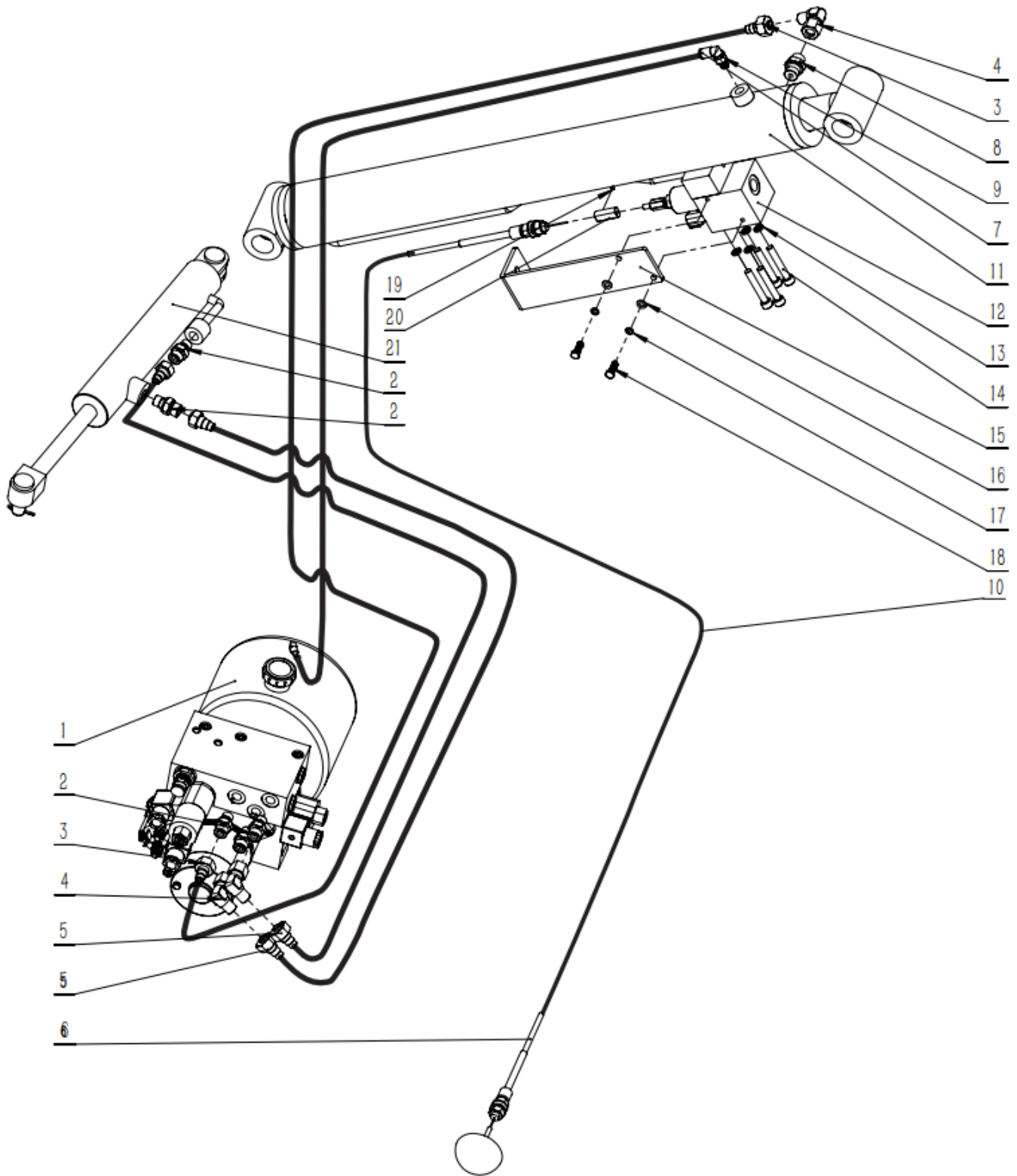

4-1 Schematic diagram of hose connection

NO.	Figure number	Name	Part number	Quantity	Remarks
1	60XEND-610000-000	Power unit	226500000001	1	
2	JT-110414-G00	Connector	226000040039	5	
3	60XEND-630003-000	High-pressure hose	226300010074	1	
4	JT-201414-G00	Right Angle Connector	226000040041	2	
5	60XEND-630001-000	High-pressure hose	226300010074	2	
6	60XEND-640200-000	Pull line	226000050005	1	
7		Nut		1	
8	JT-110614-G00	Transition joint	226000040040	1	
9	80XENS-600001-000	Pneumatic connector	226000040003	1	
10	60XEND-630004-000	Pneumatic hose	226300030002	1	
11	60XEND-620100-000	Lifting cylinder	226200010007	1	
12	60XEND-640100-G02	Cylinder valve	226400050004	1	
13	GB97.1-85	Washer 8	300030040014	4	
14	GB70-85	Screw M8×60	300040020147	4	
15	140XEN-400410-000	Pull plate	226000050004	1	
16	GB97.1-85	Washer 6	300030040013	2	
17	GB93-87	Washer 6	300030010014	2	
18	GB70-85	Screw M6×20	300040020158	2	
19	GB/T78-2007	Hexagon socket set screw M4×4	300040060007	1	
20	140XEN-400420-000	Solenoid valve cable connector	226000050004	1	
21	78XEN-620200-000	Steering cylinder	226200020001	1	

5 Electrical System

5-1 Distribution of electrical components

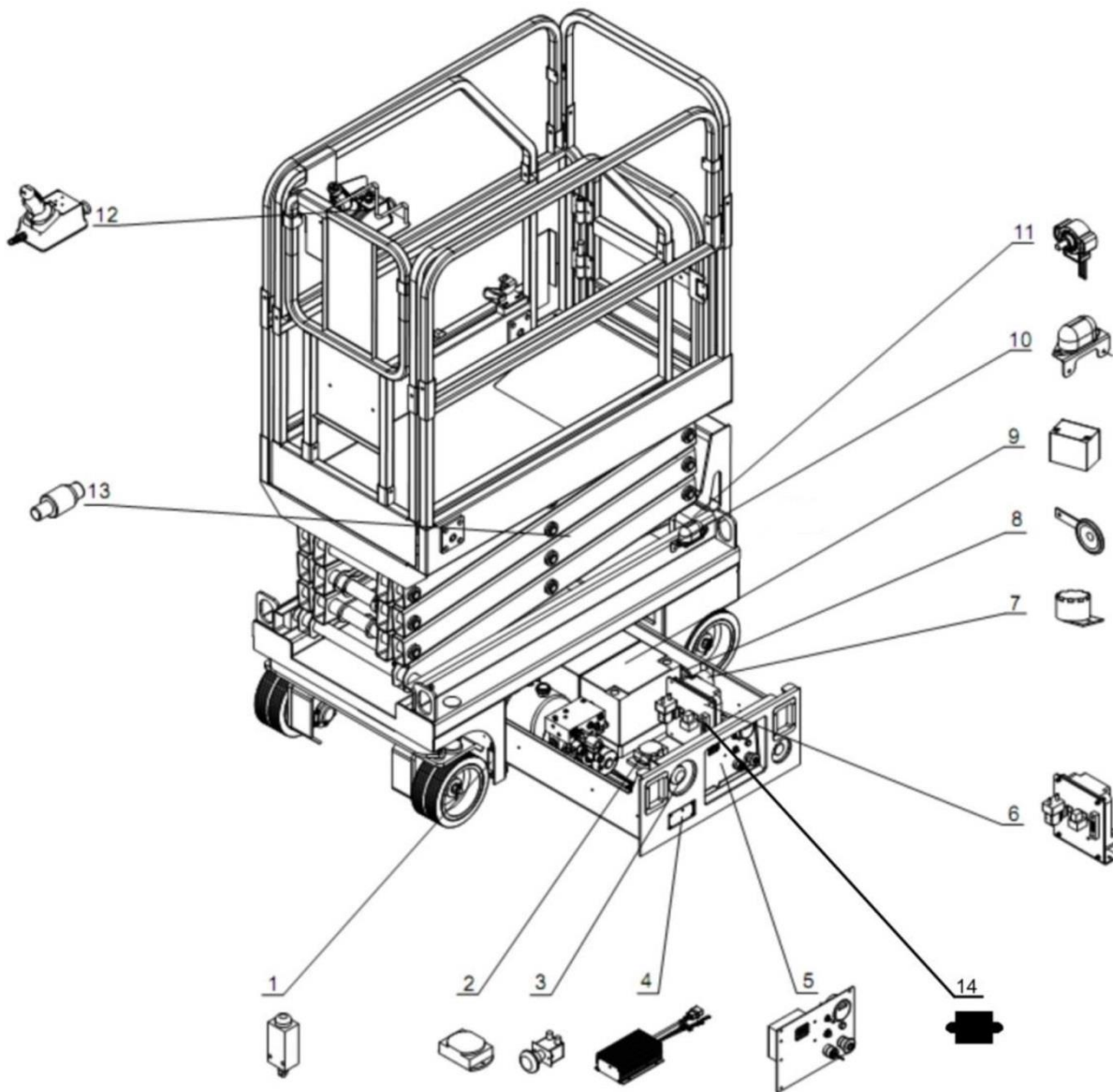

5-1 Distribution of electrical components

NO.	Figure number	Name	Part number	Quantity	Remarks
1	78XEN-740800-G00	Micro switch assembly	227200050001	2	
2	78XEN-740700-G00	Angle sensor assembly	227400010009	1	
3	78XEN-740300-G00	Main power switch	227200010001	1	
4	60XEND-760200-G00	Charger	227800010003	1	
5	60XEND-740500-000	Control panel assembly	227500000004	1	See 5-3
6		Control components			See 5-4
7	78XEN-740800-G00	Buzzer	227000020001	1	
8	78XEN-741000-G00	Horn	227000030001	1	
9	60XEND-760100-G00	Maintenance-free battery	227600020003	2	
10	78XEN-741100-G01	Police light assembly	227000010006	1	
11	60XEND-741200-G00	Potentiometer	227400010012	1	
12	78XEN-750000-G00	Joystick	227500030001	1	
13	78XEN-741300-G01	Pressure Sensor	227400020001	1	
14	60XEND-741600-G00	Power conversion module		1	

5-2 Schematic diagram of electrical connection

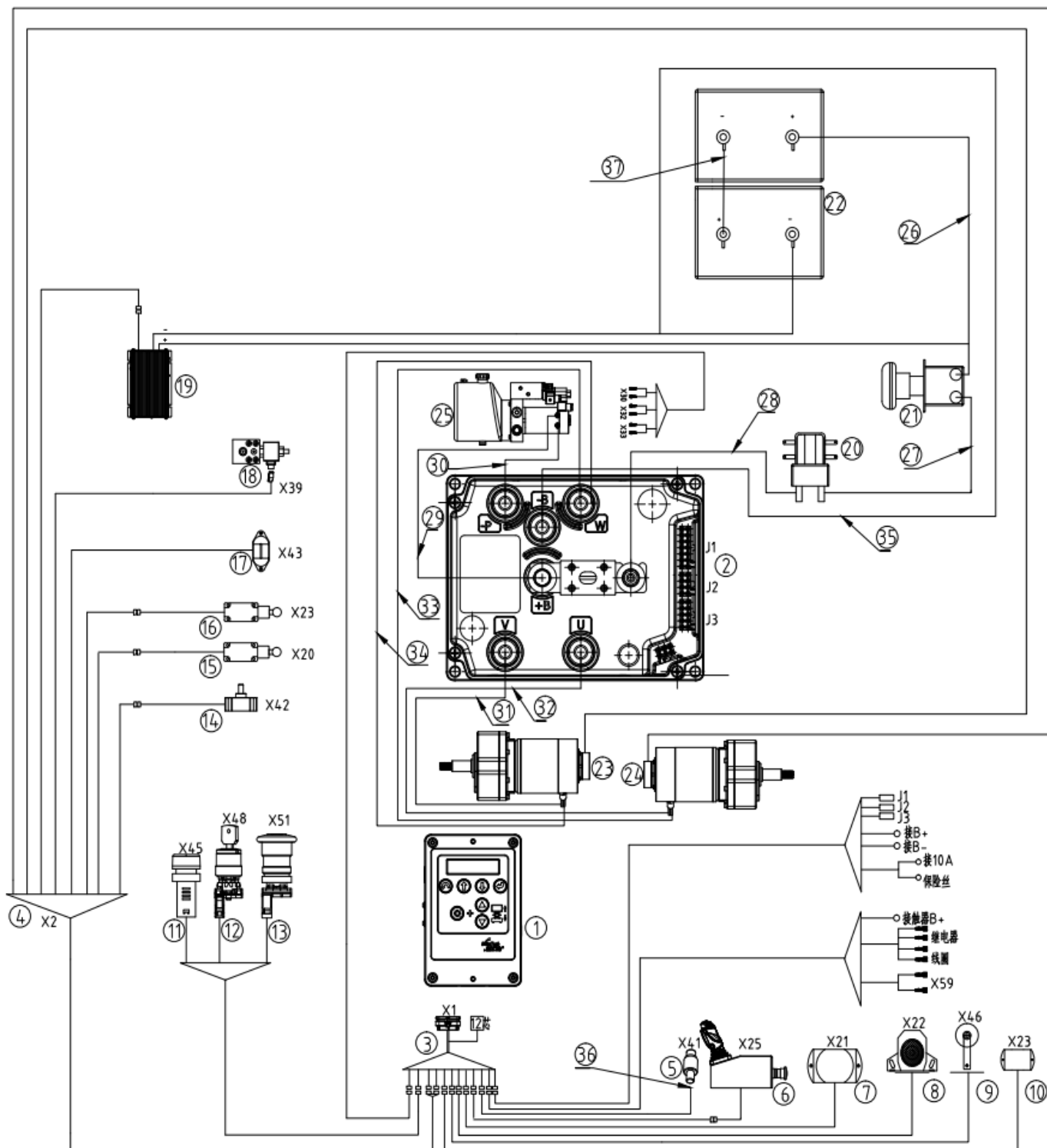

5-2 Schematic diagram of electrical connection

NO.	Figure number	Name	Part number	Quantity	Remarks
1	60XEND-740200-G00	Control module		1	DTC E500
2	60XEND-740100-G00	Driver		1	ZAPI
3	60XEND-710000-000	Main harness	227100010008	1	
4	60XEND-720000-000	Switch wiring harness	227100020009	1	
5	78XEN-741300-G01	Pressure Sensor	227400020001	1	
6	60XEND-750000-G00	Handle	227500030001	1	
7	78XEN-740700-G00	Angle sensor	227400010009	1	
8	78XEN-740800-G00	Buzzer	227000020001	1	
9	78XEN-741000-G00	horn	227000030001	1	
10	60XEND-741600-G00	Power conversion module		1	
11	78XEN-740505-G00	Red warning light	227000010002	1	
12	GTHZ120-710400-G00	Three gear key switch	227200030001	1	
13	GTHZ120-720700-G00	Emergency stop switch	227200020001	1	
14	60XEND-741200-G01	Potentiometer	227400010012	1	
15	78XEN-740600-G00	Left anti-tilt switch	227200050001	1	
16	78XEN-740600-G00	Right anti-tilt switch	227200050001	1	
17	78XEN-741101-G01	Small warning light	227000010007	1	
18	60XEND-640100-G00	Cylinder valve block	227000010007	1	
19	60XEND-760200-G00	Charger	227800010003	1	
20	60XEND-741501-G00	Contacto	227500060002	1	
21	78XEN-740300-G00	Main power switch	227200010001	1	
22	60XEND-760100-G00	Maintenance-free battery	227600020003	2	
23	60XEND-760300-G00	Left travel motor	227700020003	1	
24	60XEND-760400-G00	Right travel motor	227700020004	1	
25	60XEND-610000-000	Power unit	226500000001	1	
26	60XEND-730100-000	Cable (battery+/power switch)		1	
27	60XEND-730200-000	Cable (power switch/contacto)		1	

28	60XEND-730600-000	Cable (contactor/fuse)		1	
29	60XEND-730400-000	Cable (lifting motor/controller B+)		1	
30	60XEND-730500-000	Cable (lifting motor/controller P-)		1	
31	60XEND-731100-000	Cable (left travel motor A2/controller V)		1	
32	60XEND-731200-000	Cable (right travel motor A2/controller U)		1	
33	60XEND-730900-000	Cable (right travel motor A1/controller W)		1	
34	60XEND-730800-000	Cable (left travel motor A1/controller W)		1	
35	60XEND-730300-000	Cable (battery-/controller B-)		1	
36	60XEND-700200-000	Pressure sensor line	227100050009		
37	60XEND-730700-000	Cable (battery+/battery-)		1	

5-3 Control panel assembly

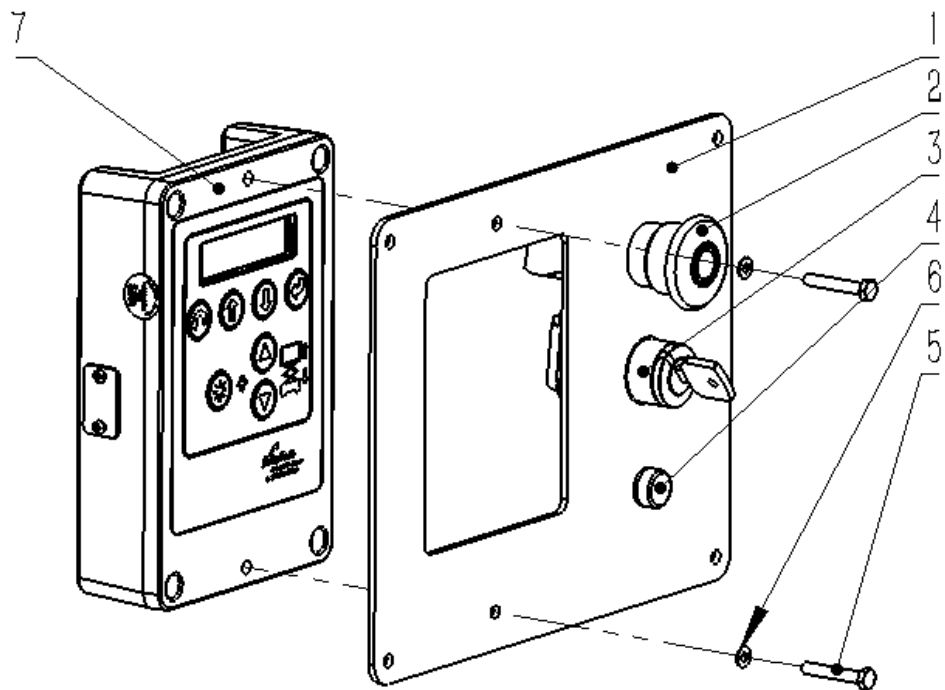

5-3 Control panel assembly

NO.	Figure number	Name	Part number	Quantity	Remarks
1	60XEND-400011-000	Control panel	227500080012	1	
2	GTHZ120-720700-G00	Emergency stop switch	227200020002	1	
3	GTHZ120-710400-G00	Three-speed key switch	227200030002	1	
4	78XEN-740505-G00	Red warning light	227000010002	1	
5	GB5783-86	Bolt M4×30	300010040132	2	
6	GB97.1-85	Washer 4	300020150008	2	
7	60XEND-740200-G00	ECU controller		1	DTC E500

5-4 Control components

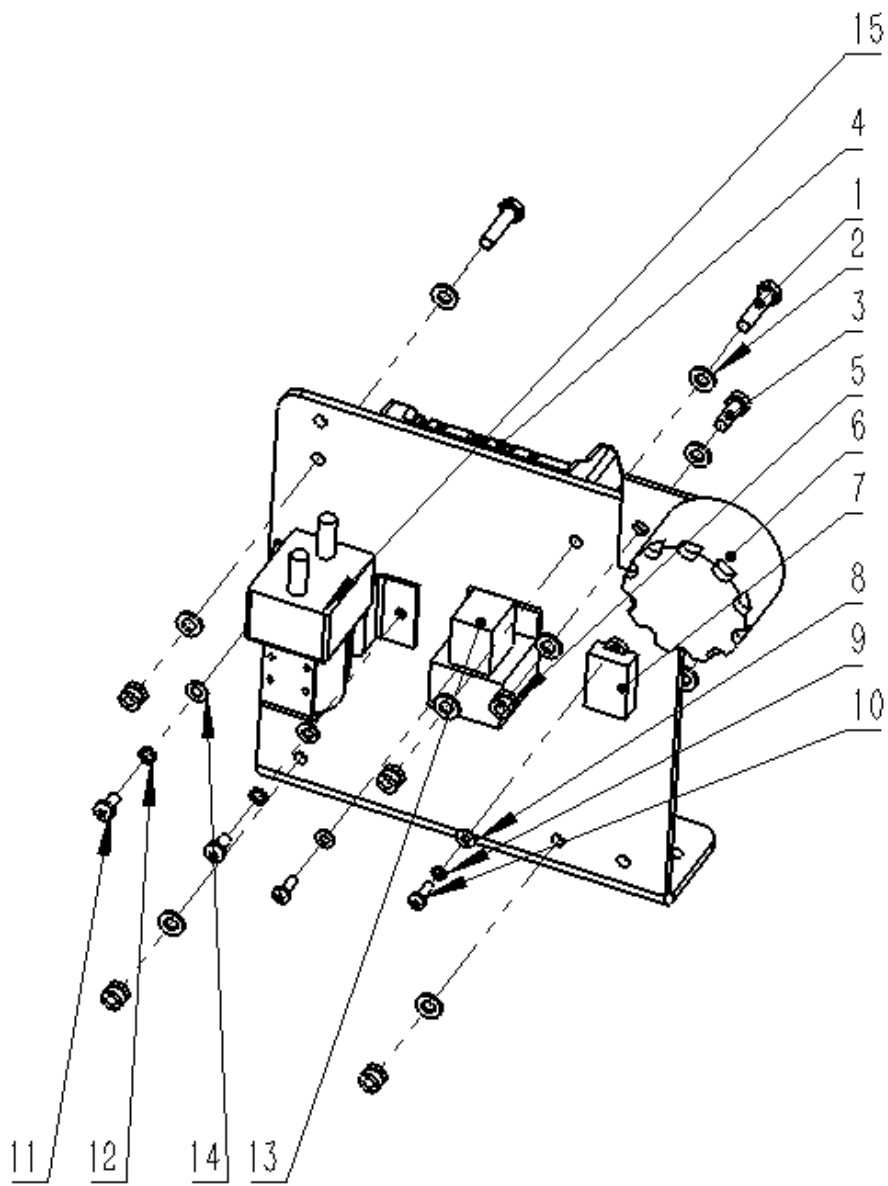

5-4 Control components

NO.	Figure number	Name	Part number	Quantity	Remarks
1	GB5783-86	Bolt M6×25	300010040148	4	Level 8.8
2	GB97.1-85	Washer 6	300030040013	10	
3	GB5783-86	Bolt M6×16		1	
4	60XEND-740100-G00	Controller	227500010006	1	
5	GB/T889.1-2000	Nut M6	300020150011	5	
6	78XEN-740800-G00	Buzzer assembly	227000020001	1	
7	60XEND-741600-G00	Power conversion module		1	
8	GB97.1-85	Washer 4	300030040011	3	
9	GB93-87	Washer 4	300030010012	2	
10	GB818-85	Screw M4×12	300040070036	3	
11	GB70-85	Screw M5×10	300040020136	2	
12	GB93-87	Washer 5	300030010013	2	
13		Relay		1	
14	GB97.1-85	Washer 5	300030040012	2	
15	60XEND-741500-G00	Contactor assembly	227500060001	1	